

NEMO

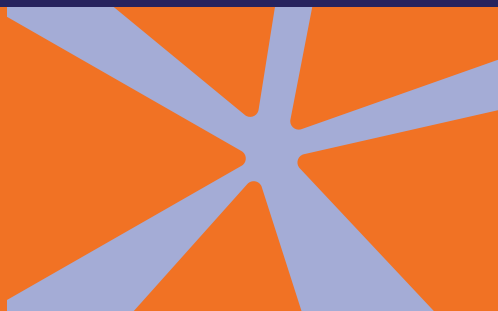



When Cyclop asks Ulysses “Who are you?”, he answers “Nobody” (Nemo in latin). Ulysses was a mighty man, yet he wanted to stay nameless when he met Cyclop.

Like Ulysses the Nemo Collection is strong but does not want to define itself with undue restrictions. Nemo will grow with you to meet the challenges of tomorrow.

STORY

6-9

NEMO SEATS

16-35

NEMO TABLES

36-49

GAME OF FORMS



NEMO COLLECTION is a mosaic-like game of forms based on trapezoids and triangles. The core idea of scaling and combining these basic forms gives Nemo its unique character. By combining different elements it is possible to create new forms and let the organism grow to meet even larger scale functional needs. Rhythm and variation is created by height alternatives.

The possibility to use different colours in upholstery, also partly in the same element, gives architects and interior designers endless chances to create unique solutions. Elements can be stable or movable by adjusting them with foot knobs or castors with brakes.

STRONG BASE AND ELEGANT DETAILS

Elegant upholstery details give Nemo sitting modules their characteristic appearance but their function is also to preserve the monolithic beauty during the years of use. Upholstery materials can be chosen among the most common textile manufacturers collections. Material can be fabric, leather, vinyl according to interior requirements.

In each Nemo sitting module there is comfortable fire-proof foam on top of a strong veneer construction. Upholstery is always done with care. Different forms and sizes make one, two or several people fit to sit, and by combining elements a whole group.



COMBINING IS LIKE PLAYING

The light appearance of the desk collection is due to thin tube dimensions and bevelled table top edges. Castors with brakes and foot knobs add usability. All models can be equipped with power charging elements. The bag hook adds convenience. Frame colours and table top materials can be made to order.

WORK, STUDY, EAT OR MEET

Like sitting modules also desks are designed with same principle. Trapezoid and triangle based forms create desks for one, two or several users. Nemo desks fit exceptionally well in today's co-working or educational environments. Due to smoothly running castors the smaller ones are easy to move and the forms meet each other without caps. Bigger models have totally different dynamics compared to normal rectangular tables, which makes them more democratic and especially suitable for creative working.

LIKE A RAY OF LIGHT

The light appearance of the desk collection is due to thin tube dimensions and bevelled table top edges. Castors with brakes and foot knobs add usability. All models can be equipped with power charging elements. The bag hook adds convenience. Frame colours and table top materials can be made to order.



NEMO Seats / Modules from left to right A55 with tray, C45, H45 and H35.
Visualization, inspired by Aalto University Töölö Campus

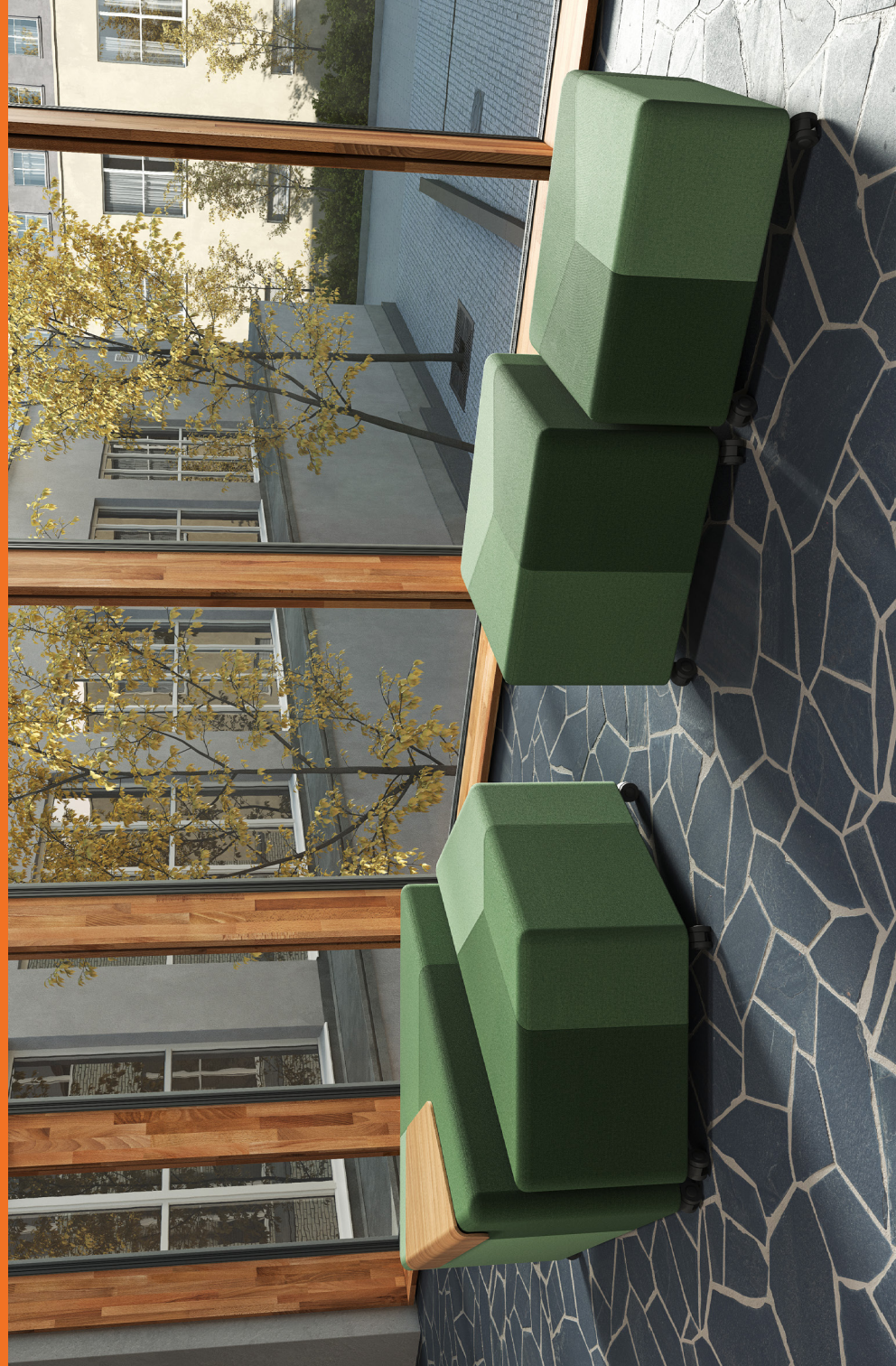
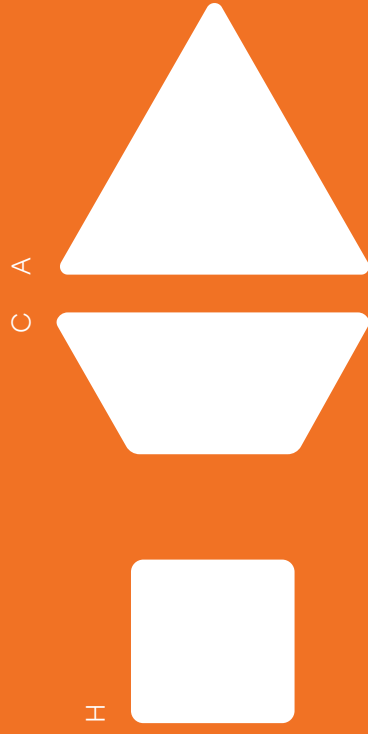

NEMO Seats / Modules in the background from left to right E45 and F45, in the foreground E45 and F45.
Visualization, inspired by Aalto University Töölö Campus

F



E



NEMO Seats & Tables / Nemo Seats in the foreground from left to right DR45, G55, DL45, all with trays. Nemo Seats in the classroom B45, B55 and Nemo Tables in the classroom 2a, 4
Visualization, inspired by Aalto University Töölö Campus

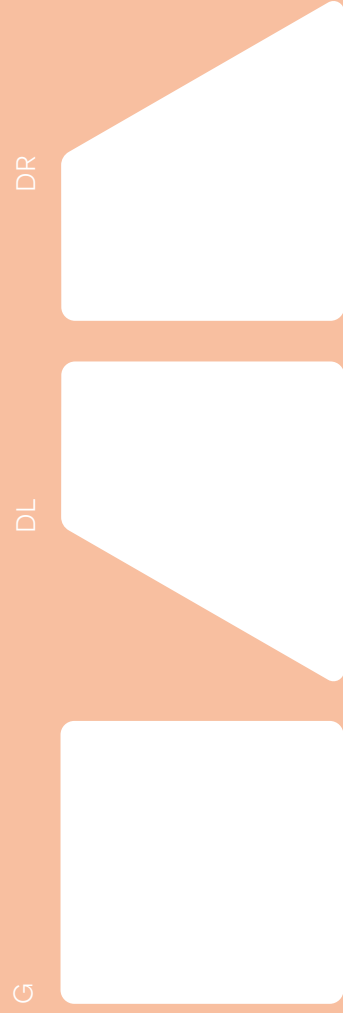

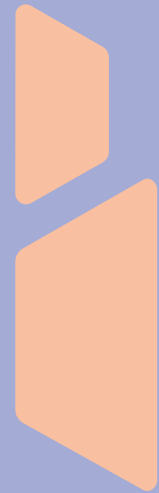

NEMO Seats

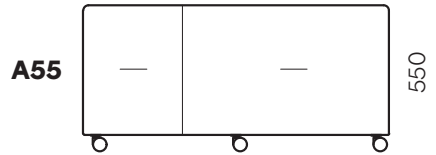
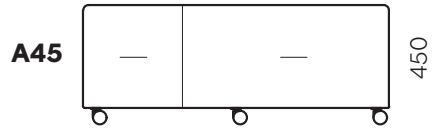
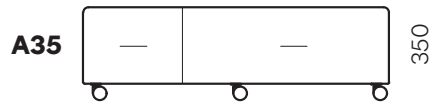
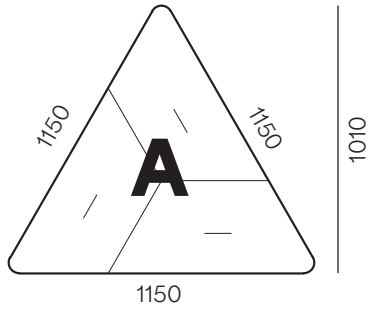

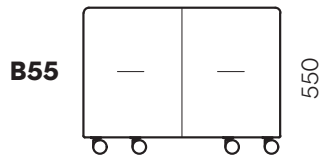
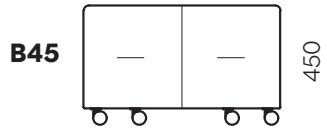
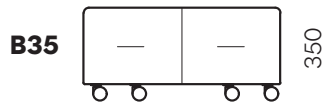
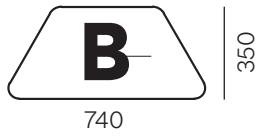

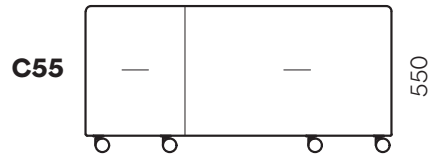
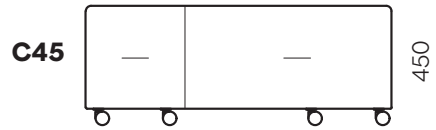
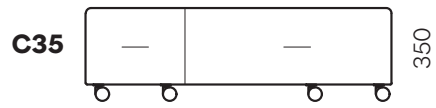
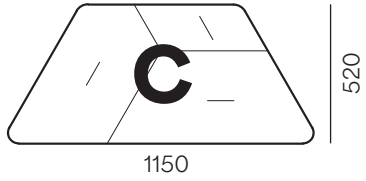

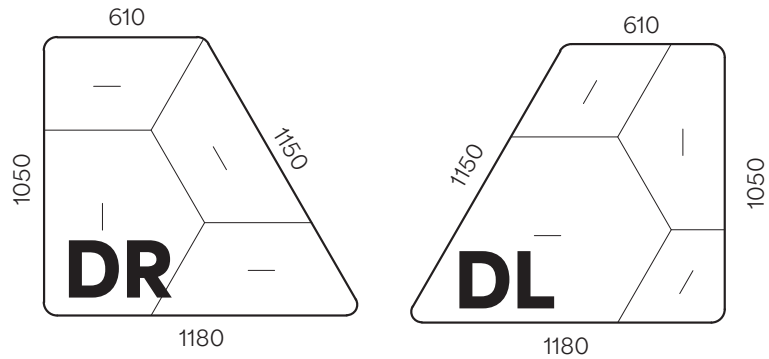

DL/DR35

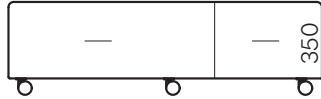

DL/DR45

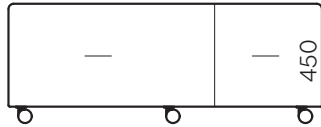

DL/DR55

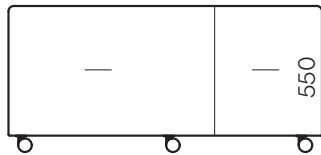

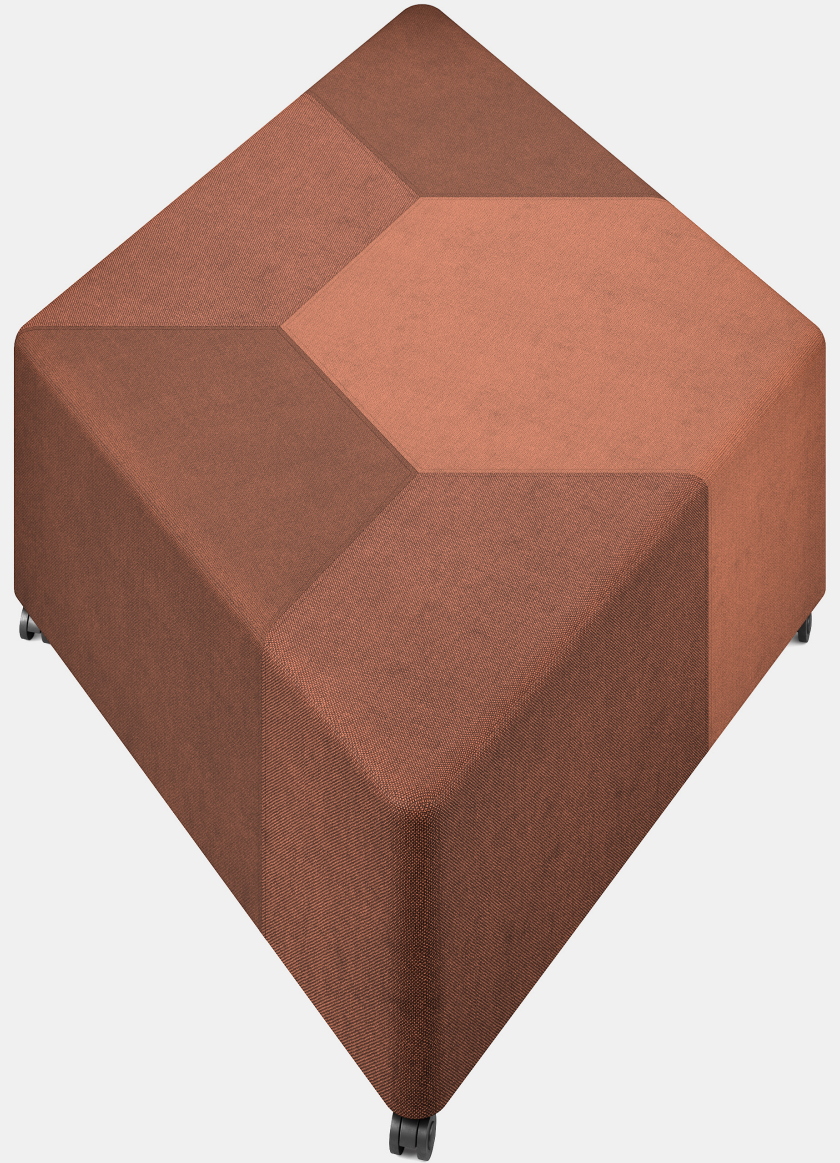
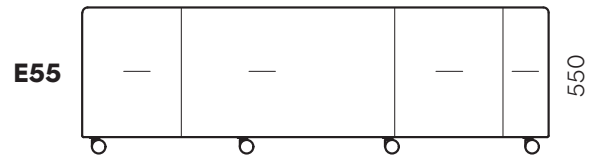
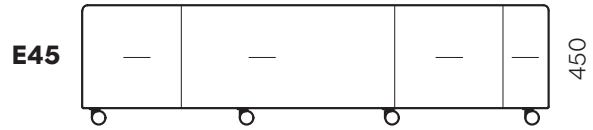
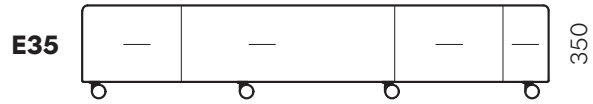
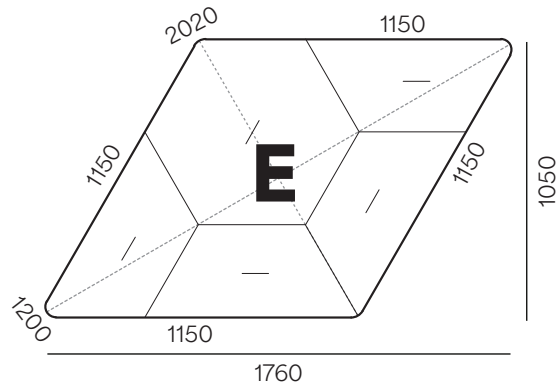

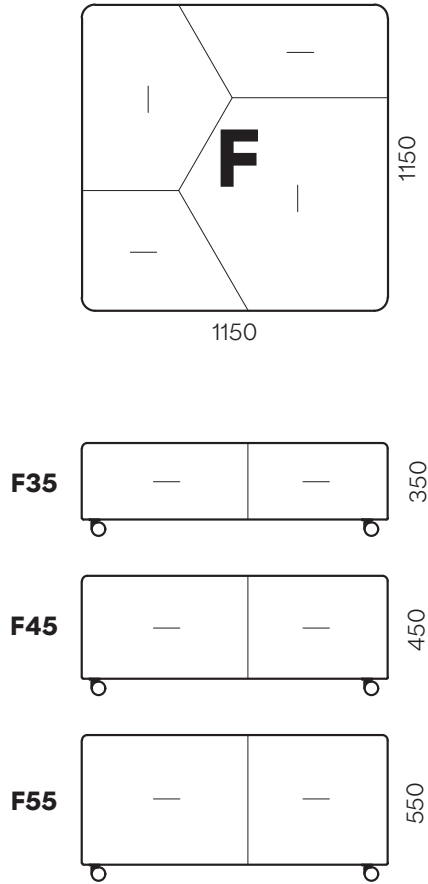

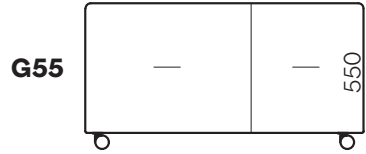
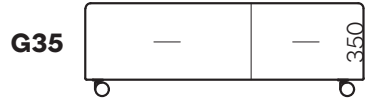
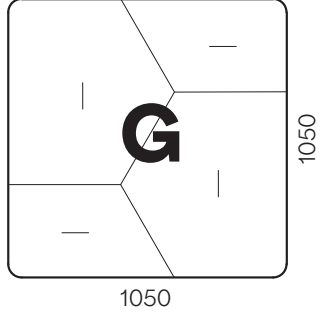

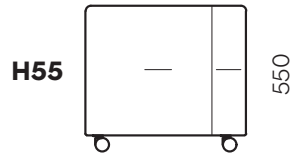
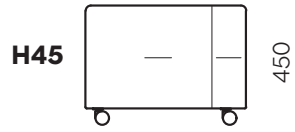
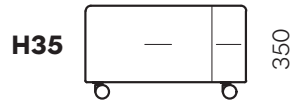
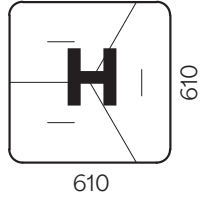

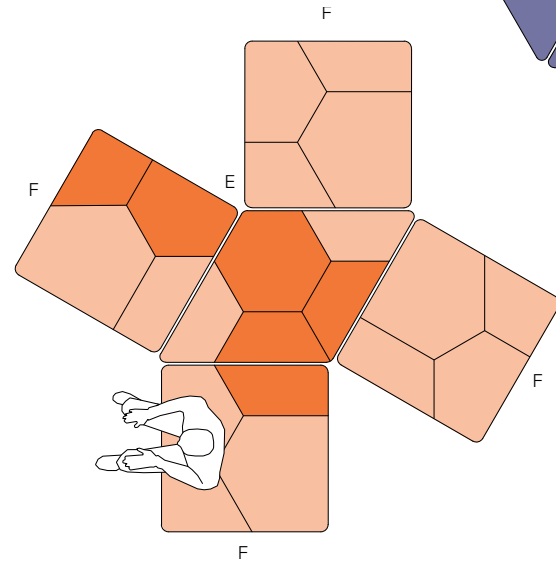
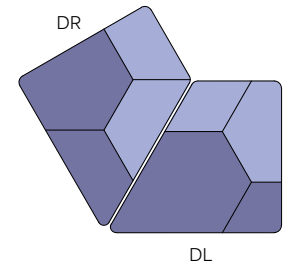
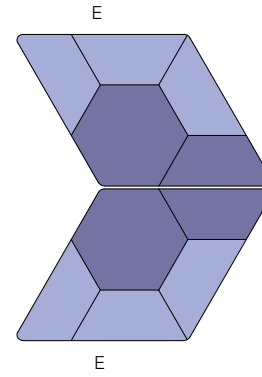
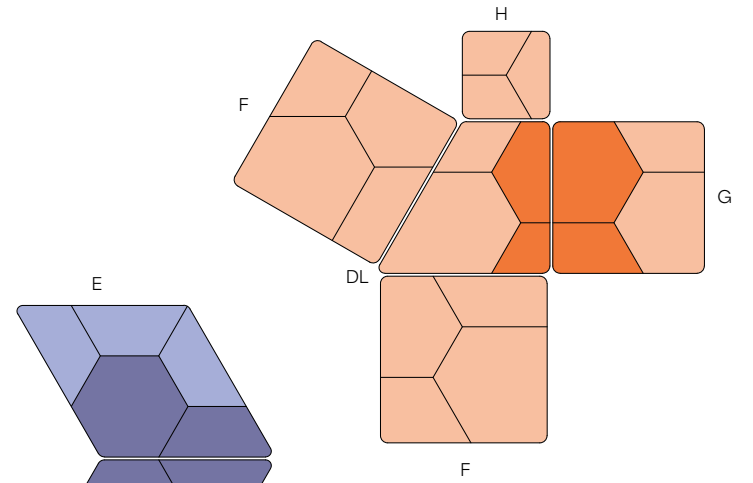
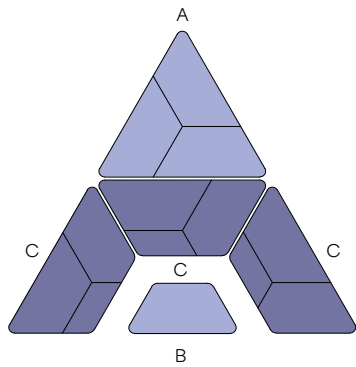
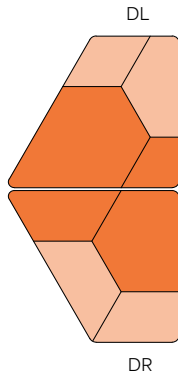
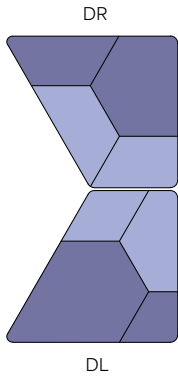
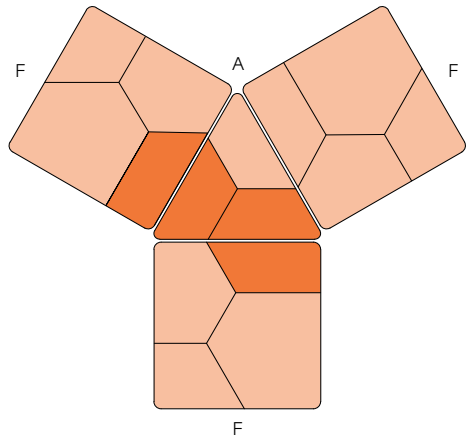

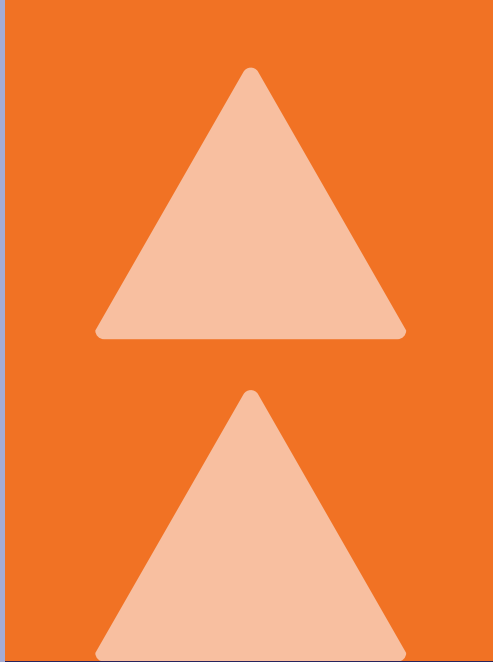
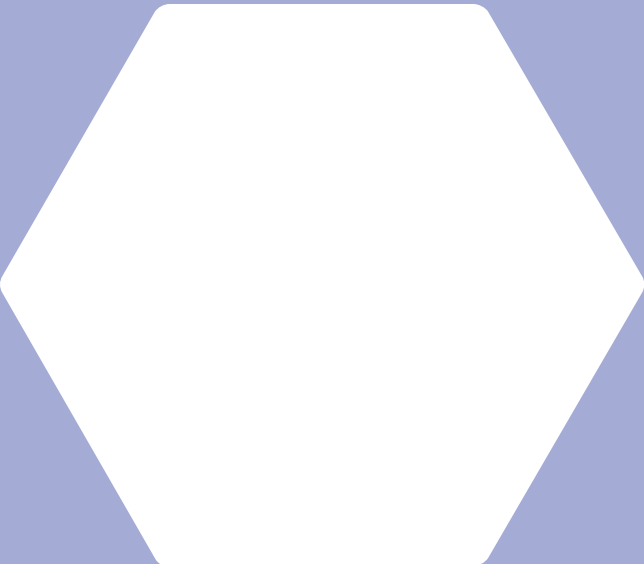

NEMO Tables



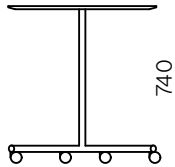
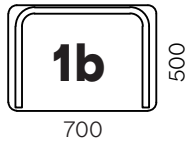
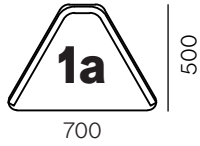

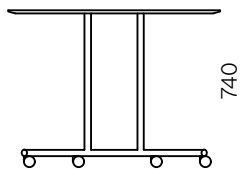
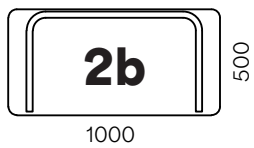
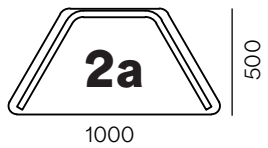

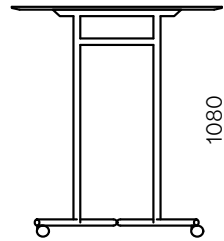
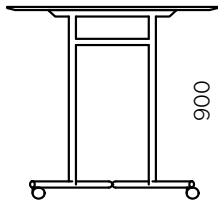
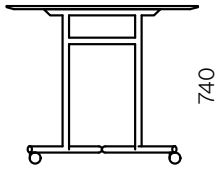
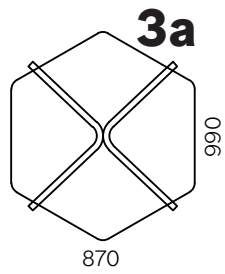
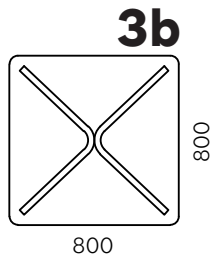

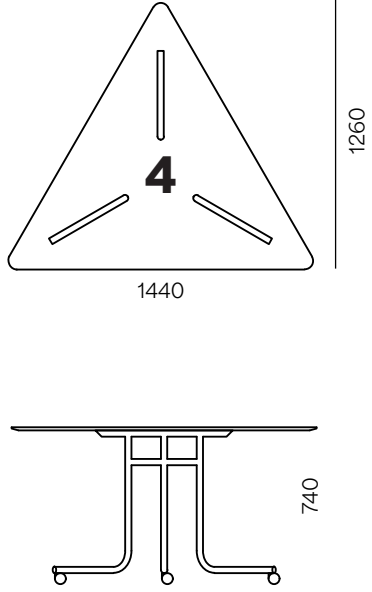

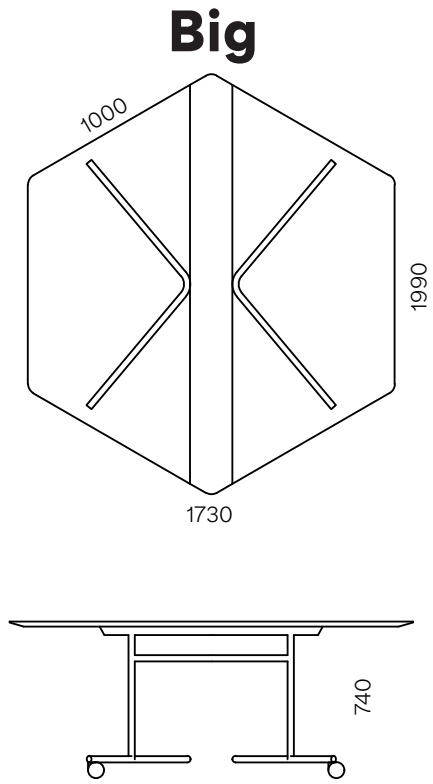

Monster

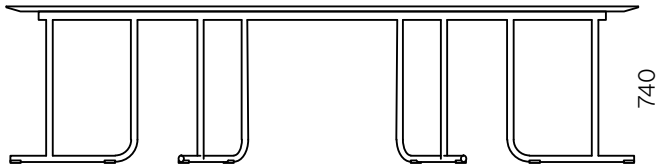
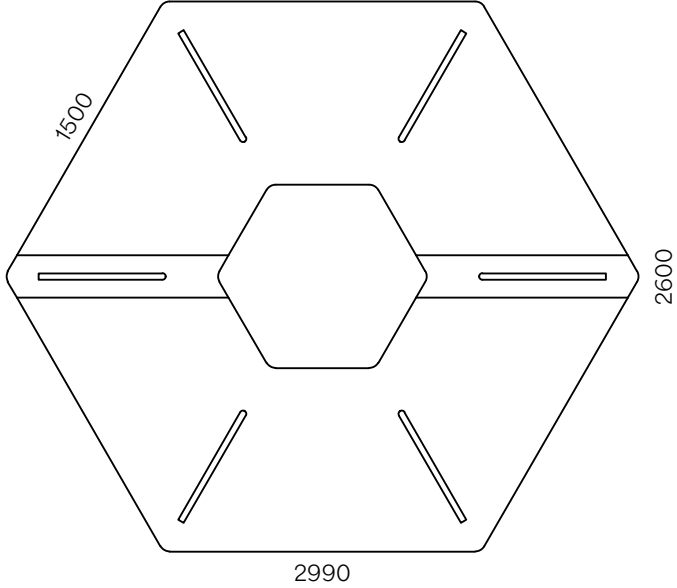

JOUNI LEINO

My father worked as an architect. As a child I always considered his job boring, just sitting and drawing. When my art teacher at school urged me to apply to art and design university, I got annoyed. (I was afraid of artistic looking girls.) My mother paid the travel costs to the exam. I reluctantly left. So strange how people end up doing what they do!

Later I have been asked to run a design professorship, perform in interior design program in television and act as an external examiner in a university abroad. I have received few international awards for my designs as well. So, thanks all you nice people!

Designing Nemo has been a voyage. In the beginning there was merely the obsession for trapezoids and triangles. Interior-Agents forced me to transform this mind-game into usable furniture. Through failures and successes we have now reached a point when we can proudly launch the collection.



INTERIOR-

AGENTS



These are exciting times for us. We are proud to present the Nemo collection, the first collection of the company Interior-Agents for you. We came a long way through an intensive debate and a holistic development process with Jouni Leino, the designer of Nemo collection. To find your own way and create something new is never an easy work to do. We feel that we found our own way. That is why we are especially proud to show you in this catalogue the versatility of Nemo products and inspire you to design your own Nemo seating module or table with the help of endless combination options.

We are located in the city of Kuopio, in the middle of the beautiful Finnish lake and forest area. It is an astonishing place to live but at least so astonishing place to work. You have a strong connection to the nature every day and every moment. By working in such area the way of working sustainably is a natural choice.

Nemo was developed to last long and to use as little natural resources as possible, still offering an enjoyable user experience. We sincerely hope that you enjoy the narrative of Nemo and make it alive in your own design projects.

Jukka Niskanen
Founder of Interior-Agents

NEMO SITS

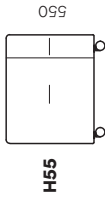
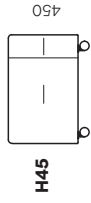
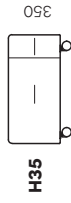
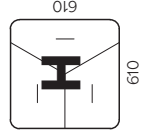
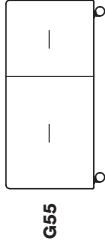
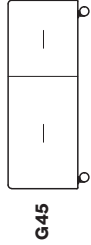
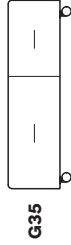
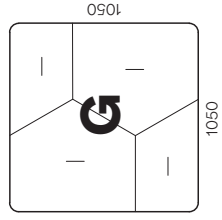
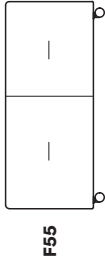
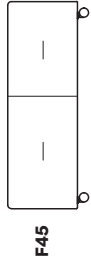
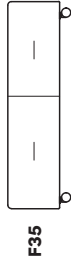
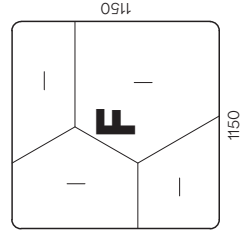
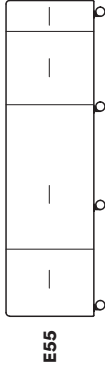
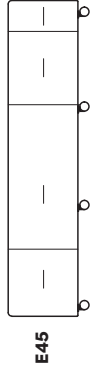
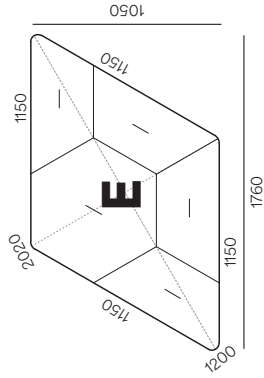
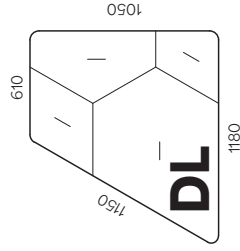
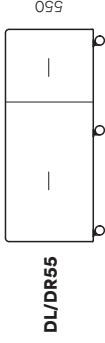
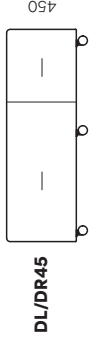
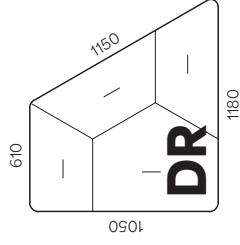
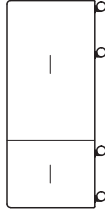
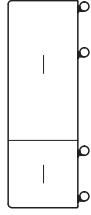
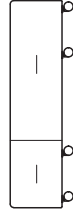
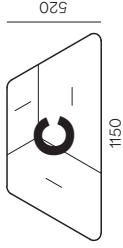
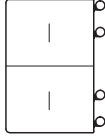
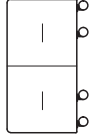
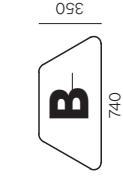
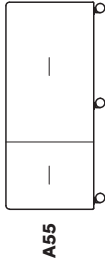
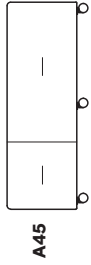
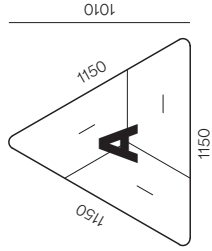

NEMO Tables

